

SYNERGY MINI



Digital Broadcasting Center

User Guide

© 2019 Tract Company

Table of Contents

1. Congratulations on your purchase of SYNERGY MINI!	1
1.1 Equipment	1
1.2 Warranty	1
1.3 Transportation and storage	3
1.4 Safety instructions	3
1.5 Precautionary measures	5
2. Meet SYNERGY MINI	6
2.1 Specifications	7
2.2 Simplified structural scheme	10
2.3 Power on. System settings	11
3. Overview of panels, controls, indications and connectors	12
3.1 Front panel	13
3.1.1 Fader and its working mode	13
3.1.2 Channel control and indication	13
3.1.3 Control panel and display	19
3.1.4 Display and Main menu	22
3.1.5 Web interface	30
3.2 Back panel	32
4. Channels	34
4.1 Microphone channels	34
4.2 Telephony channel	35
4.3 External analog linear stereo input	36
4.4 External digital AES/EBU stereo input	37
4.5 External digital Internet stereo input	37
4.6 Internal digital sound buses	37
4.7 FM-receiver	38
4.8 Outputs of the mixing console	38
5. Connectors	41
6. Remote control, broadcast alarm and power supply	46
7. REC 1, REC 2, REC 3 modes	48
8. Updating the software version	52
9. Software supplied with SYNERGY MINI	53
9.1 Diagram of connection via network	54
9.2 DIGISPOT II SYNERGY Installation and configuration	54

9.2.1 DJin SYNERGY 56
9.2.2 IAudio Service 57

1 Congratulations on your purchase of SYNERGY MINI!

SYNERGY MINI is not just a mixing console, but a multifunctional center for digital broadcasting that allows you to record, edit and broadcast your own radio programs “on the air” or to the Internet. Besides, SYNERGY MINI is also a rebroadcasting center. The console allows you to submit an external channel from a satellite receiver, codec or Internet stream to the software output of the console.

To use all the functions of SYNERGY MINI and enjoy the using of the console, it is recommended to study the installation and control functions described in this manual.

Additional information is available on the website <http://news.digispot.ru> or in the technical support service support@tract.ru.

1.1 Equipment

Package contents:

?	Name and type	Quantity
1	SYNERGY MINI	1
2	Power Supply Mean Well GST25A12-P1J	1
3	Power Supply for external display “MIC ON” Arlight ARDV-12-12A, 12V, 1A, 12W	Option
4	Power cable, European corner plug - European connector C13	1
5	Grounding kit (cable 2.8m, screw DIN7985 M4)	1
6	Adapter "plug F - TV socket"	1
7	FM antenna	1
8	Software for SYNERGY MINI (on USB-flash)	Option
9	Technical description	1
10	User guide	Option

1.2 Warranty

This product is manufactured in the Russian Federation by The **Tract** Company.

The manufacturer guarantees that the equipment will work normally if it is installed and used in compliance with the conditions of operation, transportation and storage.

Warranty period: 12 months from the date of transfer of the product to the consumer.

In the case of malfunction, register it and return the defective console to The **Tract** Company or their authorized representative for warranty repairs. Warranty repairs are provided to the following conditions:

1. The equipment was installed and used in accordance with the instructions of the user manual.
2. The equipment was operated properly and as intended; was not damaged by accident or negligence; has not been modified otherwise, as described in the user manual or allowed by The **Tract** Company.
3. All the necessary adjustments, changes or repairs were carried out by The **Tract** Company or its authorized representative.
4. This warranty does not cover physical damage of the conductive layers of the faders.
5. The defective equipment (with the original power supply unit) should be returned to The **Tract** Company or their authorized representative (delivery - at the buyer's expense) with a document confirming the purchase.
6. The returned product must be packed in its original factory packaging in order to avoid damage in transit.

In case of violation of conditions and rules of using of the console during the warranty period, the consumer lose the right to free warranty repair or replacement.

The reasons for removing the console from the warranty service are:

1. Mechanical damage (chips, dents, etc.) on the body or another part of the console, indicating the impact;
2. Traces of foreign substances inside the console: liquids, objects, insects and rodents;
3. Signs of self-repair or opening of the console;
4. Violation of seals, stickers; replacement of parts and components;
5. Damage that is a direct consequence of violation of the rules of operation, including: incorrect installation of the console, supply of high or unstable supply voltage, hot plug, disregard of the rules of electrostatic safety, etc.;
6. Damage caused by climatic conditions, natural disasters, fires and similar causes.

The product is designed and manufactured in accordance with:

- GOST 11515-91 Sound broadcasting channels and paths;
- GOST IEC 60065-2013 Audio, video and similar electronic equipment. Safety requirements;
- GOST EN 55103-1-2013 Section 5 and 8. Electromagnetic compatibility of technical equipment. Electromagnetic interference from professional audio, video, audiovisual equipment;

- GOST 32136-2013 Section 5. Electromagnetic compatibility of technical equipment. Resistance to electromagnetic interference professional audio, video, audiovisual equipment.

Copyright © 2019 **Tract** Company. All rights reserved.

1.3 Transportation and storage

Transportation of the product in the packaging of the manufacturer can be carried out in any type of closed transport.

The transport position is not specified, mounting on vehicles should exclude the possibility of moving products during transportation.

The storage of products is allowed in a heated ventilated room at an ambient temperature of +1C to +40 ° C and relative humidity up to 80%.

The expiration date should not exceed the warranty period of the product.

The blocks in the package must be protected from the installation of other loads weighing more than 5 kg.

1.4 Safety instructions

Warning! Read the following before work:

Read the instructions!	Keep safety and operating instructions. Follow all warnings listed here and on the console. Follow the instructions for use presented in this user guide.
Do not open the console!	It is forbidden to open the console! In case of opening the console during the warranty period, the warranty does not apply.
Connection:	Connecting the console can be done only in the switched-off state.
Power supply:	Connect the console only to those power sources, which voltage corresponds to the specified in this user guide. Use a power cord with a non-separable plug, conforming to local standards.
Power cable routing:	Lay the power cable so that nobody goes on it, does not stretch it and does not put any objects on it.

Grounding:

The console must be grounded!

Water and humidity:

To avoid the possibility of fire or short circuit, do not expose the console to rain or moisture and do not use it in wet or humid conditions. Do not put any containers with liquids that may spill into the holes of the console.

Ventilation:

Do not block the ventilation holes and do not place the console where there are no conditions for air circulation.

Heating and vibration:

Do not use the console in places subject to excessive heat and direct sunlight. Keep the console away from equipment that is a source of increased heat generation and vibration.

Service:

Immediately turn off the console and unplug the power cable if it exposed to moisture, if liquid has spilled on it, if different objects have got inside, if the plug or power cable is damaged, if the console is working during a thunderstorm, if smoke, smell or noise comes out of it. Contact for any maintenance only to qualified personnel.

Installation:

Install the console according with the instructions set in the manual. Use audio connectors only for their direct purpose.

Plug replacement:

SYNERGY MINI comes with a power cord with a non-folding plug.

When replacing the plug, follow the instructions below. The power cord color corresponds to the following marking:

		PIN	Core color
			Euro USA/ pe Canada da
L	Phase		Brown Black n
N	Zero		Blue White
E	Ground		Green

Yellow
w-
green

The yellow-green core must be connected to a pin marked with the letter E or a ground symbol. The console must be grounded.

The blue core must be connected to the pin marked N.

The brown core must be connected to the pin labeled L.

When replacing the plug, be sure to observe the color coding.

1.5 Precautionary measures

Damage:

Do not place heavy and sharp objects on the control panel and avoid vibrations and careless handling; this can damage the console and spoil its appearance.

Terms of Use:

During using and storage, protect the console from dirt, dust, heat, vibration, tobacco ash and smoke, liquid ingress and exposure to rain and moisture. If the console is wet, turn it off immediately and unplug the power cord. Let the console dry before re-starting work.

Cleaning:

Do not use chemicals or abrasives, as well as solvents. The control panel is best cleaned with a soft brush and a dry lint-free cloth.

Transportation:

Protect the controls against damage during transport.

Hearing:

Avoid excessive volume when working with sound systems, as this may damage your hearing. This also applies to working with headphones. Prolonged exposure to high volumes may cause hearing loss at certain frequencies or in a wide range of frequencies.

2 Meet SYNERGY MINI

SYNERGY MINI is a multifunctional center for digital broadcasting that allows you to record, edit and broadcast your own radio programs “on the air” or to the Internet, as well as provide retransmission.

All functions related to Internet streams are provided only with a computer connected to the console — a workstation with SYNERGY MINI software installed on it.

Ease of use, ease of operation, optimal functionality and low price make it attractive for different organizations and an ideal solution for many tasks.

The SYNERGY MINI console has **eight channels (faders)**, with audio sources attached to the input of each channel:

- Channel **1** - microphone 1, usually the lead microphone (DJ);
- Channel **2** - microphone 2, usually the first guest microphone (Guest 1);
- Channel **3** - microphone 3, or the second guest microphone (Guest 2), or the input balanced analog stereo line, or the stereo output of the internal FM receiver.

Microphone channels have a sufficient adjustment range to use as line inputs. If necessary, you can connect a microphone through an external microphone processor.

- Channel **4** is a channel with switchable inputs:
 - output of a built-in telephone hybrid, to which an analog telephone line is connected, a telephoneor
 - Bluetooth-module (abbreviation - **BT**), through which communication is established with an external GSM-phone or other Bluetooth-enabled device;
- Channels **5**, **6**, and **7** use AoIP audio streams (FoxxWire or Dante protocol — optional) as input, usually, to connect virtual players to an audio workstation;

The AoIP interface with FoxxWire provides playback of eight stereo streams from a workstation to the inputs of the console and eight stereo streams from the outputs or internal buses of the console to the workstation, with bidirectional transmission of control commands.

- Channel **8** is a channel with switchable inputs:
 - second analog stereo lineor

- digital AES/EBU stereo line
- or
- Internet stream (AoIP).

SYNERGY MINI contains **two outputs for the main stereo program**: balanced analog stereo output and digital AES/EBU output. **The console recording bus** connects to the workstation via AoIP.

The mixer has **headphone outputs** and two guests with separate volume control, as well as access to **acoustic control monitors** with automatic shutdown logic.

In addition, SYNERGY MINI contains a built-in **FM-receiver**, which can be used to monitor and record the broadcast, as well as an input source.

The SYNERGY MINI console provides **microphone-activated (MicLive) alarm output** in active (with optional power supply) and passive modes, as well as **4 GPOs** for external control.

A multifunctional **touchscreen** with level gauges and menus for selecting modes and settings is built into the console.

The body of SYNERGY MINI is made of metal, which gives additional protection and structural strength.

Standard connectors for connecting sources and destinations simplify system deployment.

2.1 Specifications

General characteristics of SYNERGY MINI:

Parameter	Value
Power consumption, not more	24 W
Power supply (from power supply)	+12 V
Power Supply	Mean Well GST25A12-P1J
Power supply for external display (optional)	Arlight ARDV-12-12A
Type of power supply connector	plug 2.1x5.5 mm
Supply voltage (power supply)	220 V
Main voltage frequency	50 Hz
Sizes without packaging	440x310x80 mm
Packed sizes	580x440x130 mm
Unpacked weight	3,6 kg

Shipping Weight	4,6 kg
-----------------	--------

Input/Output Parameters for SYNERGY MINI

Microphone input (Mic 1,2,3) *	
Transfer ratio/analogue	+ 6 dB...+ 69 dB
Input resistance, not less	850 Ohm (maximum gain)
Frequency response (20Hz - 20kHz)	+0/-1.5 dB (maximum gain)
Input noise level, not more	-124 dBu (R is. 200 Ohm)
Phantom power	+48 V (on/off)
Maximum Input Level	+ 18 dBu (minimum gain)
Analog Stereo Input (Line in, Ext in) *	
Maximum Input Level	+ 24 dBu
Nominal input level (selected in the mixer settings)	+4 dBu or -10dBV
Input resistance, not less	30 kOhm
Frequency response (20Hz - 20kHz)	+/-0.5 dB
THD Distortion + Noise (at +24 dBu), no more	0.05% (Line in), 0.3% (Ext in)
Dynamic range, not less	95 dB
Crosstalk no less	100 dB (at 1 kHz)
Telephone hybrid input (POTS)	
Frequency range	300 ... 3400 Hz
Maximum Input Level	- 12 dBu (at 1% CED)
Crosstalk	> -18 dB (1 kHz send/receive)
Bluetooth hybrid input	
Interface	Bluetooth 3.0 (HSP and A2DP)
Analog output (PRG Out) **	
Maximum output level	+ 24 dBu
Frequency response (20Hz - 20kHz)	+0/-0.3 dB
THD Distortion + Noise (at +24 dBu), no more	0.05%

Output impedance	50 Ohm
Monitor Output (Monitor Out) **	
Maximum output level	+ 18 dBu
THD Distortion + Noise (at +24 dBu), no more	0.01%
Headphone output (HPH: Dj, Guest1, Guest2) **	
Output power (at THD + Noise no more than 0.2%)	130 mW (32 Ohm) 9 mW (600 Ohm)
Frequency response (20Hz - 20kHz)	+0/-0.5 dB
Dynamic range, not less	80 dB
Digital I / O (PRG Out AES, Ext in AES)	
Format	AES-3 (AES/EBU)
In / out. resistance:	110 Ohm
Frequency converter sampling rate (SRC) at the input:	32 ... 192 kHz
Output level, not less	3.4 V (at R n = 110 Ohm)
Output signal capacity	24-bit
Output Sampling frequency	48 kHz
External display output Red Light (connector RCA Out)	
Maximum voltage through key	No more 48 V
Maximum current through key	No more 500 mA
Output type (without power connection to the Power connector)	GPO
Outputs GPO	
Number of outputs	4
Maximum voltage through key	No more 35 V
Maximum current through key	No more 50 mA

2.2 Simplified structural scheme

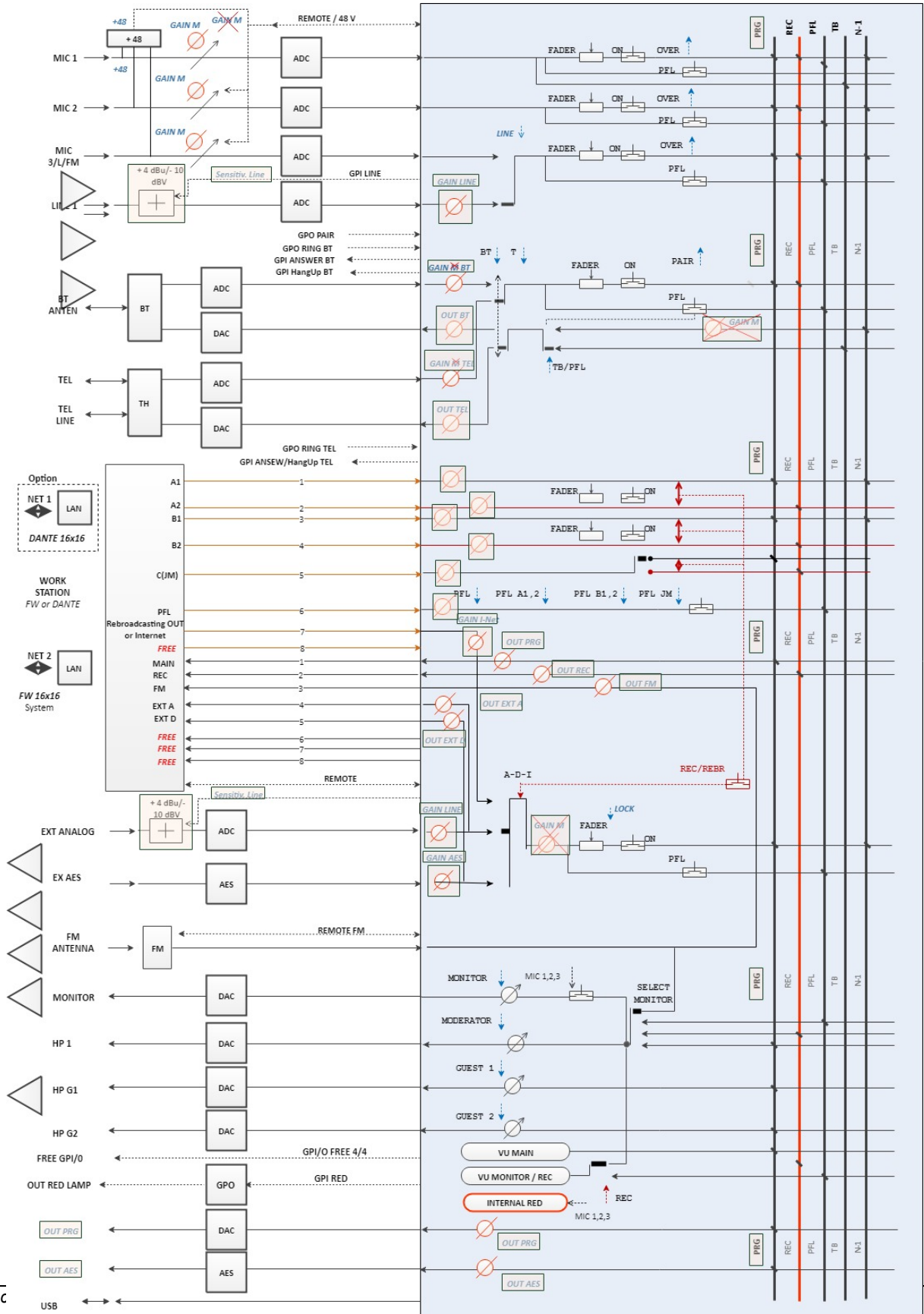

2.3 Power on. System settings

Before using the mixing console, need to do the next:

- place SYNERGY MINI on the workplace;
- ground the case of the mixer with a cable;
- connect the workstation to the mixer connector of the Net 2 using a patch cord;
- connect consumers and signal sources to the outputs and inputs of the console;
- power up the mixing console using the power supply unit Mean GST25A12-P1J.

When power is applied, the operating system is loaded. After the appearance of the graphical interface on the screen, the mixer is ready for using.

Attention!

When the + 48V phantom power is switched on, switching the signal sources to the mic 1-3 Mic inputs is prohibited. These actions can break the microphone inputs.

Switching the sources of the signal to the microphone inputs Mic 1-3 on a running mixer with open microphone channels is not recommended. At this point, clicks, background noise may appear in the microphone channel.

Software and ASIO driver installation

The SYNERGY MINI software suite consists of the DIGISPOT II software (in a special configuration for working with the mixing console) and the ASIO FoxxWire driver for transmitting audio streams.

Software distribution and installation instructions can be found on the web-page: [SYNERGY MINI Mixing Console](#).

Network Interface Settings:

Net2 default network interface settings:

IP: 192.168.1.10 MASK: 255.255.255.0

The mixer IP-address can be changed via the menu on the LCD-screen:

Menu - System - IP-address - specify the address on the on-screen keyboard.

Connecting a computer - workstation to the mixer:

To connect a workstation to the mixing console, specify the IP-address and MASK from the same subnet as the console in the properties of the computer network card.

For example:

IP: 192.168.1.100 MASK: 255.255.255.0

3 Overview of panels, controls, indications and connectors

On the front panel there are the main controls, display and display information. These include faders, LED buttons, LED indicators and encoders.

On the right side of the front panel is the Touch Screen LCD display with level indicators and other information. Using the display an additional control of the mixing console and its operational setting is made.

All LED-buttons and LED-indicators have a backlight with light-lilac color.

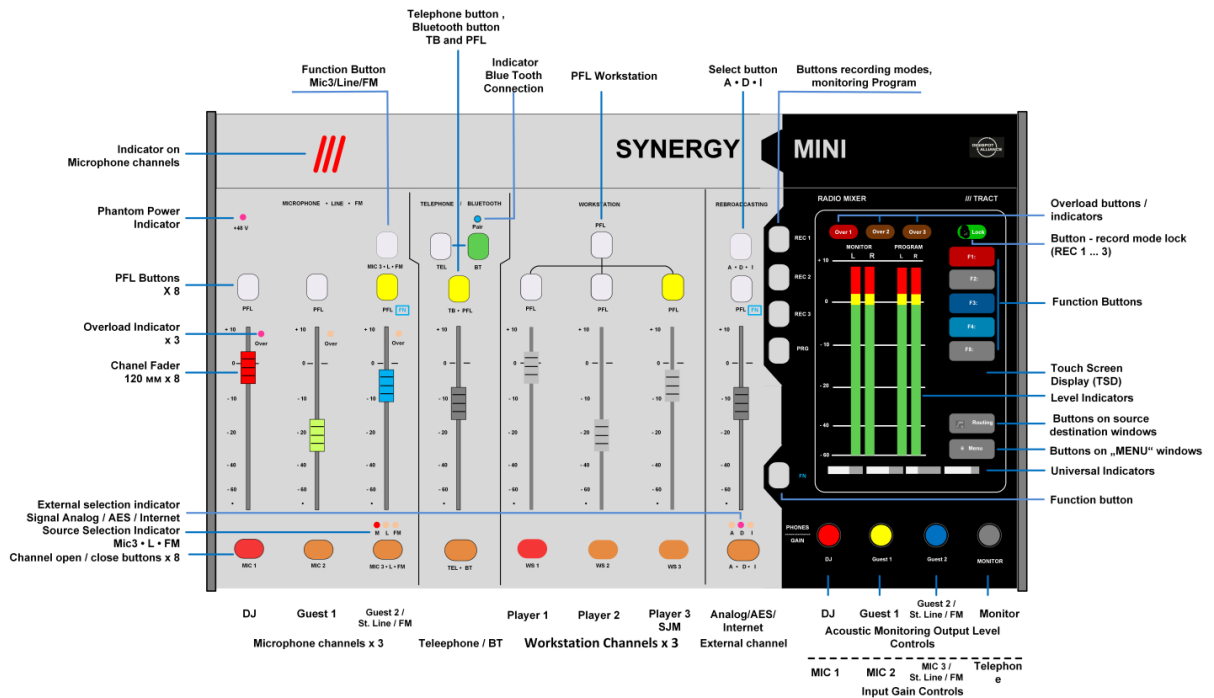

On the back panel of the mixing console there are connectors for sources and receivers of the audio signal and control.

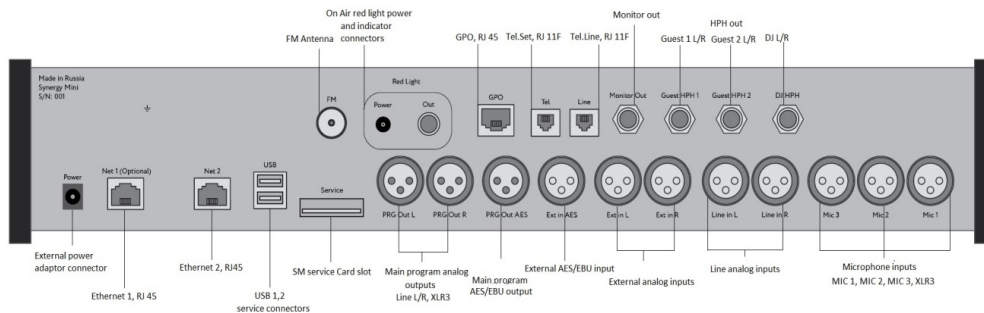

3.1 Front panel

3.1.1 Fader and its working mode

The **fader** is the primary gain control for each channel. The sensor is an ALPS slider potentiometer with a non-linear logarithmic characteristic setting the fader scale. The stabilized voltage is applied to the fader. The fader slider contact voltage is fed to the eight-bit ADC and then to the console's computing module for calculation and formation of channel transfer ratio.

A channel fader in combination with a channel open button located directly below the fader provides channel on/off, i.e. giving a sound signal from a channel input to a program bus or a recording bus.

There are 3 channel enable modes that can be selected in **Menu - System**:

1. **Fader** mode. Shifting the fader from the bottom position provides opening and switching the channel, with the channel open button is bright red. In this mode the button is passive and only displays the status of the channel.
2. **Button** mode. When the button is pressed and the fader is extended, the channel is opens and switches to certain buses, the channel open button lights up in bright red. Pressing the button again closes the channel.
3. **F+B** mode. This mode combines the functions of the Fader and Button modes. In the initial state, the button is turned off, and the fader is in its lowest position. Two ways of working are possible:
 1. Channel control mode from the button. The fader is set to the desired value, and the button is light red (ready mode). In order to open a channel, it's necessary to press the button. When the channel is open, the button is bright red. When pressing it again, the channel closes and the button becomes light red again. When closing the fader with the channel open, the button will light up in red, i.e. the channel control function is transferred to the fader - its shift up and down will open or close the channel. To return to the initial state, need to press the active button and move the fader all the way down.
 2. Channel control mode from the fader. Pressing a button converts its color from background to light red, shifting the fader to the desired value from the lower state opens the channel. All manipulations on the transition to the initial state and the change of methods to control the channel are similar to those described above.

3.1.2 Channel control and indication

Input microphone channels, stereo line channel and FM-channel

The first two channels are microphone, the third channel is combined: you can choose a microphone channel, a linear stereo channel or an FM tuner.

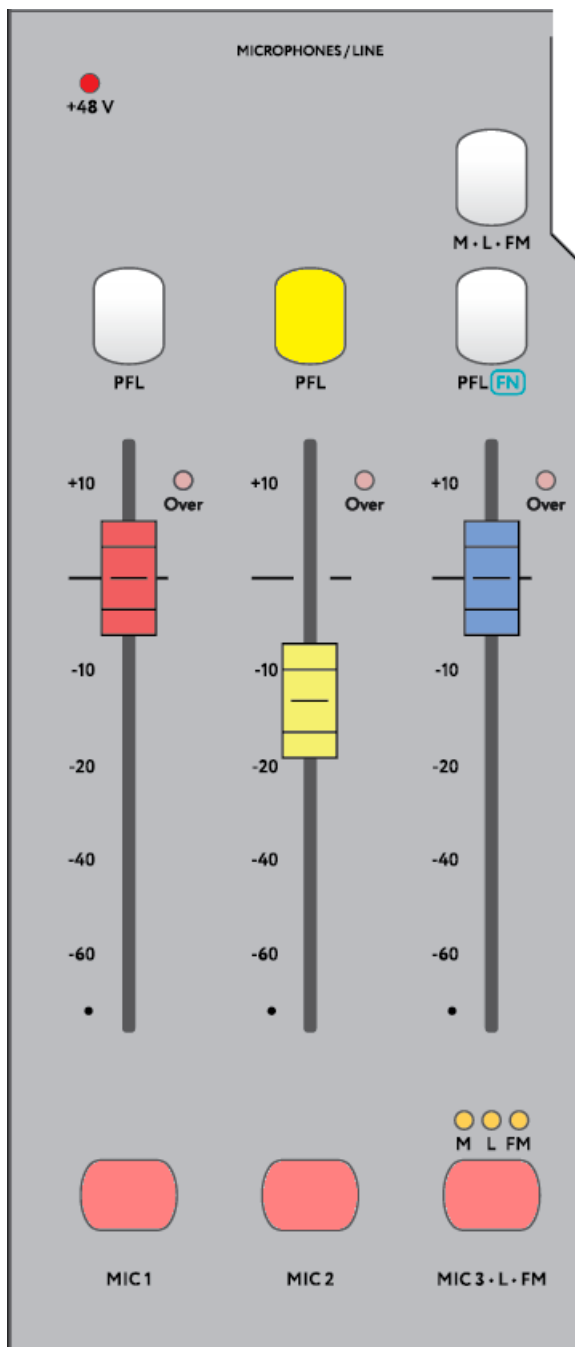

+ 48 V - Phantom power supply indicator to the microphone connectors and their further supply to the condenser microphones. Red LED indicator. Inclusion is made for all channels at once on the touchscreen in **Menu - Inputs**.

M · L · FM – Input source select button, allows to select a source on channel 3 (either a microphone, or a line-in input, or an FM tuner output). The indicator button without fixing, the color is lilac when pressed.

M – Lit indicator corresponds to the microphone on ? 3 to input channel ? 3.

L - Lit indicator corresponds to the inclusion of the stereo line to the input channel ? 3.

FM - Lit indicator corresponds to the activation of the signal from the output of the FM receiver.

PFL (Pre-Fader Listening) – 3 indicator buttons for pre-listening channels, the color is yellow when pressed. Can work simultaneously.

In order to select a source in channel 3, you need to press the **FN** button on the right side of the console and pressing the **PFL (FN)** button to select the desired source. In the pre-listening mode, the LED indicators (**M · L · FM**) are yellow.

Over – LED indicators (color is red) in each microphone channel. Switching on is automatically in case of overload. Switching on and off, parameters of detection and handling of overload in each microphone channel are set by means of the web-interface on the **Inputs** tab.

M · L · FM – Indicators of the selected source, color - red.

MIC 1...MIC 2...MIC 3 · L · FM – Red indicator buttons for opening channels.

Pressing the button leads the appropriate channel to the air. When activating any microphone channel, the output of the signal to external acoustic monitors (Mute Monitor Out) is turned off. On the front panel, turning on microphones is displayed in red.

Broadcast Telephony Channel

The fourth channel is a channel of a combined broadcast telephony. Channel sources may be or analog phone line or devices, with Bluetooth.

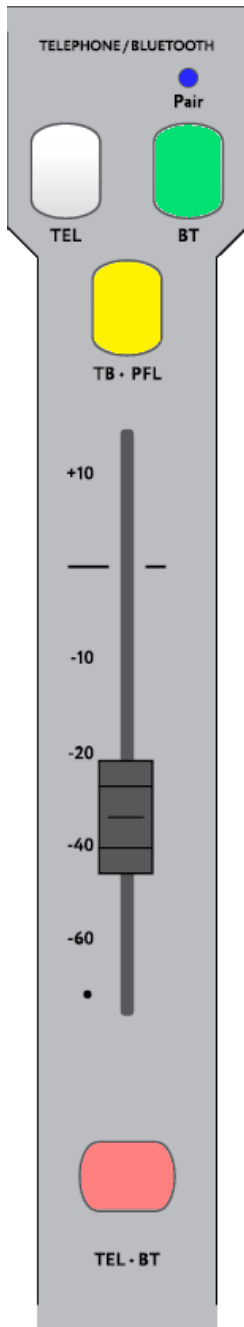

Pair - Blue LED indicates that two-way communication is established via **Bluetooth** between the external device and the mixing console.

TEL (Telephone) – Indicator button used to turn on the on-air telephony channel, when pressed, is green. The input channel sensitivity setting in **TEL** mode is made in the **Menu - Inputs** window on the touch screen.

BT (Bluetooth) – Indicator button to turn on the on-air telephony channel for transmitting signals via Bluetooth. The green button color indicates subscriber connection, blue indicates the inclusion of a stereo stream using Bluetooth. The input channel sensitivity setting in **BT** mode is made in the **Menu - Inputs** window on the touch screen.

TB • PFL (TalkBack/PreFader Listening) – Button (when pressed - yellow) turning on the mode of off-air conversation of the DJ with the person via telephone line or via Bluetooth.

TEL • BT - Indicator button, when pressed - red. Pressing the button leads the appropriate channel to the air, pressing again turns off the channel.

Digital Workstation Channels

The inputs of channels 5, 6, 7 of the mixing console are connected to the outputs of a digital workstation (WS).

The console receives output digital streams from WS via FoxxWire AoIP.

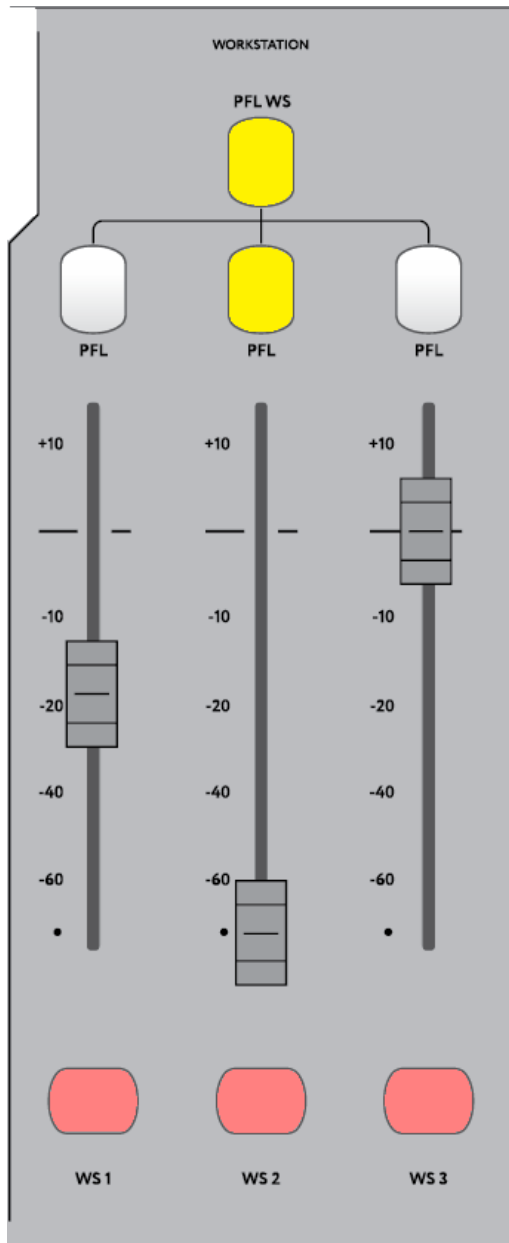

PFL WS (PreFader Listening) – Button for general pre-listening, when pressed - yellow. The button turns on monitoring of the selected file in WS, incl. from the Media database (MDB).

PFL (PreFader Listening) – Buttons for individual pre-listening, when pressed - yellow. The buttons turns on the monitoring mode of players **WS1**, **WS2**, **WS3**.

WS1, WS2, WS3 – Buttons to open channels. The background color is lilac. When the channel is ready for broadcast, the button color becomes light-red. Pressing the button leads the corresponding channel to the air, and the button becomes bright-red.

External channel

One of three external lines (through which external programs are sent for rebroadcasting to the console outputs) can be connected to the input of channel 8.

By external lines audio programs can be supplied in formats of analog stereo lines, Digital AES/EBU stereo lines or Internet Stereo Stream, coming from WS output via AoIP.

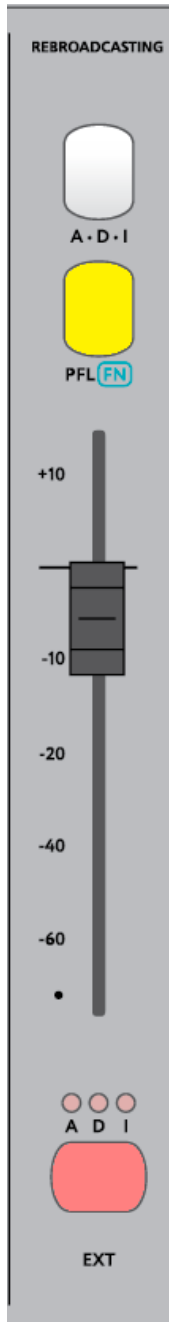

A • D • I – Button to select the input source, without fixing, when pressed - lilac color. By pressing the button successively, the source is selected at the channel input:

A - analog stereo line.

D - digital AES/EBU stereo line.

I - Internet Stereo Stream.

PFL(FN) (PreFader Listening) –

Button for pre-listening input signals to the fader, when turned on - yellow. It turns on the monitoring mode for the selected source channel (A, D or I). The source is selected by successively pressing the PFL (FN) button while simultaneously holding the **FN** button. In the pre-listening mode, the LED indicators (A, D, I) are yellow.

A • D • I - LED indicators at the bottom of the mixing console, displaying the selected program input line in red.

EXT - Button to open the channel. The background color is lilac. When the channel is ready for broadcasting, the color of the button becomes light-red. Pressing the button brings the corresponding channel on the air, and the button color becomes bright red.

3.1.3 Control panel and display

The control panel consists of control buttons, encoders, Touch Screen Display (TSD), which supports system and channel settings, and indicators of sound signal levels.





REC 1, REC 2, REC 3 – Record mode selection buttons (presets), when turned on are red.

PRG – The button for program monitoring (pre-listening), when turned on is yellow. It activates the monitoring mode of the **PROGRAM** bus - the main software bus of the mixing console. Turning on the **PFL** buttons in any of the 8 channels of the console turns off the **PROGRAM** button and switches the monitoring tools to **PFL** mode. Pressing the PRG button allows to return to monitoring the main program.

FN – Functional indicator button without fixing. When pressed it has a bright lilac color. It changes the functions of other buttons:

- **FN** with the third channel PFL button allows to select the *ML/FM* source for pre-listening.
- **FN** with the eighth channel PFL button allows to select the *A/D/I* source for pre-listening.

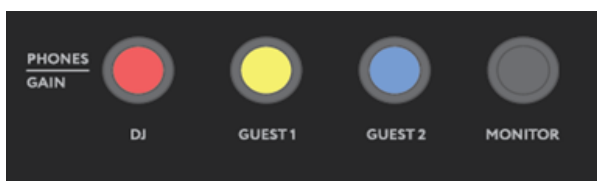

Encoders DJ, Guest 1, Guest 2 and MONITOR

The color range of encoder handles corresponds to colors of the fader handles in the channels. It allows to easily navigate when adjusting and controlling.

Encoders are directly connected with histogram indicators located at the bottom of the display. These indicators display the different values and

parameters regulated by the encoders, namely:

- Volume level in headphones and acoustic monitor;
- Input sensitivity (GAIN) of the first four channels;
- The level of reception/transmission with telephone (mobile) communication.

Encoders function in the following modes:

1. **Adjust the monitoring volume level** (default mode)



The rotation of the corresponding encoder adjusts the volume of the sound in the headphones of DJ, Guest 1, Guest 2 and at the MONITOR output; conditional images of the volume levels are produced with histogram-type indicators below TSD;

2. **Adjust the input sensitivity**



By short pressing any of the first three encoders, the **GAIN** sensitivity adjustment mode is activated for the microphone and telephony channels input. At the same time, the input sensitivity of the **MIC 1** is controlled by the **DJ** encoder, the **MIC 2** - by the **Guest 1** encoder, the **MIC 3** - by the **Guest 2** encoder and the **TEL • BT** - by the **MONITOR** encoder. The conditional images of sensitivity levels are produced by histogram-type indicators and digital values in dB at the bottom of the TSD.

The sensitivity adjustment for each of the three inputs of channel 8 is made in analog or digital format:

- for MIC 1 input: in the range + 6 dB... + 69 dB (1 dB step);
- for MIC 2 input: in the range + 6 dB... + 69 dB (1 dB step);
- for MIC 3 input: in the range + 6 dB... + 69 dB (1 dB step);
- for stereo line or FM tuner output: in the range of +/- 24 dB (0.5 dB step).

3. Adjusting the level of reception/transmission in telephony channels



A short press of the **MONITOR** encoder switches on the mode for adjusting the level of receiving and sending signals from the telephone line and the Bluetooth communication channel. In this case, the receive level from the telephone line is adjusted by the **DJ** encoder, and the gain level of the signal in it is encoded by **Guest 1**. The receiving level of the input signals on the Bluetooth line is controlled by the **Guest 2** encoder, and the gain level by the **MONITOR** encoder.

The group of encoders goes the default mode within 5-7 seconds if none of them has been pressed.

3.1.4 Display and Main menu

The main window of the Touch Screen Display consists of:

- Virtual buttons of different colors. The color depends on the modes;
- Stereo indicators of histogram sound levels - **MONITOR** and **PROGRAM (PRG)**;
- Histogram indicators showing the levels or status of **DJ**, **Guest 1**, **Guest 2** and **MONITOR** encoders.

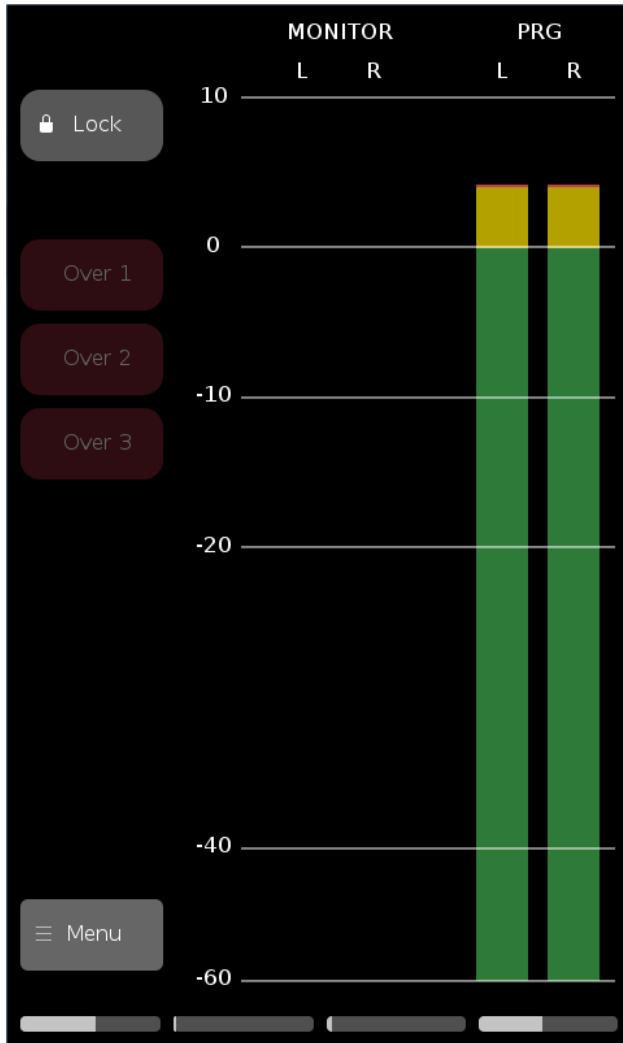

Lock - virtual button for blocking a rebroadcasting channel, the background color is gray. The **Lock** button becomes active only when the **EXT** button is red and turned on. The pressed **Lock** button turns green and locks the **REC** mode **1, 2, 3** and the state of channel 8. At the same time, the **EXT** button becomes bright green. Pressing **Lock** again deactivates the **REC 1, 2, 3** and channel 8, the **Lock** button becomes gray again, and the **EXT** button turns red.

OVER 1, OVER 2, OVER 3 - virtual buttons-indicators of the overload detection subsystem and automatic adjustment of the sensitivity of the input microphone amplifiers in the **MIC1, MIC2** and **MIC 3** channels.

The background color is red. Channel overload detection changes color to bright-red while the channel gain decreases. When pressing this button, the channel gain returns to the original value set manually by **Menu-Inputs** and the button color becomes background.

Menu - button-indicator, background color is gray. Pressing the button opens the system menu.

MONITOR is a stereo indicator of audio signal levels on the PFL bus. In the modes **REC1, REC2, REC3** it indicates the levels of sound signals on the **REC** bus, the inscription above the indicators changes to **REC**.

PROGRAM is a stereo sound level indicator on the main program bus.

Pressing the **Menu** button opens the Main menu and allows to make the following settings:

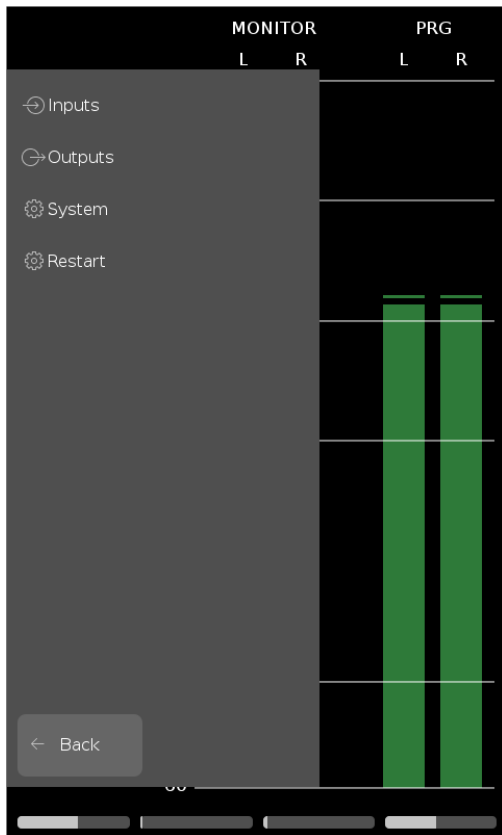

Inputs - the window is intended for setting up incoming streams.

Outputs - the window is intended for setting up outgoing streams.

System allows to make general settings of the mixing console and get some technical information.

Restart allows to restart the mixing console.

Back returns to the Main window.

Pressing **MENU - INPUT** opens the input stream settings window.

In the upper right corner of the **Inputs** window there are buttons **MIC**, **TEL**, **EXT** that allows to switch between streams to configure, the active button is yellow.

To confirm the settings and returns the TSD to the system menu state, need to press the **OK** button at the bottom of the window.

To cancel the set parameters and returns the TSD to the system menu state, need to press the **Cancel** button at the bottom of the window.

Parameter values can be set in the following ways:

- using a virtual slider. Touching the slider and moving it, you can set the desired value. The current parameter is displayed on the level indicator and in the value window.

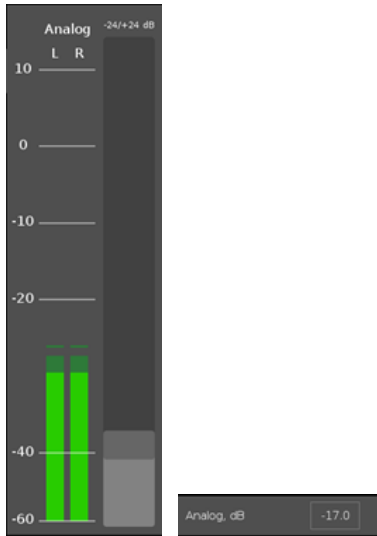

- using digital input. Touching the parameter value window on the display opens the digital input editor in which the required parameter value is entered. To apply the parameter, press **OK**.



The **MIC** button in the **Inputs** window opens the **MICROPHONES - LINE - FM** window and allows to tune microphone channels, line input and **FM**.

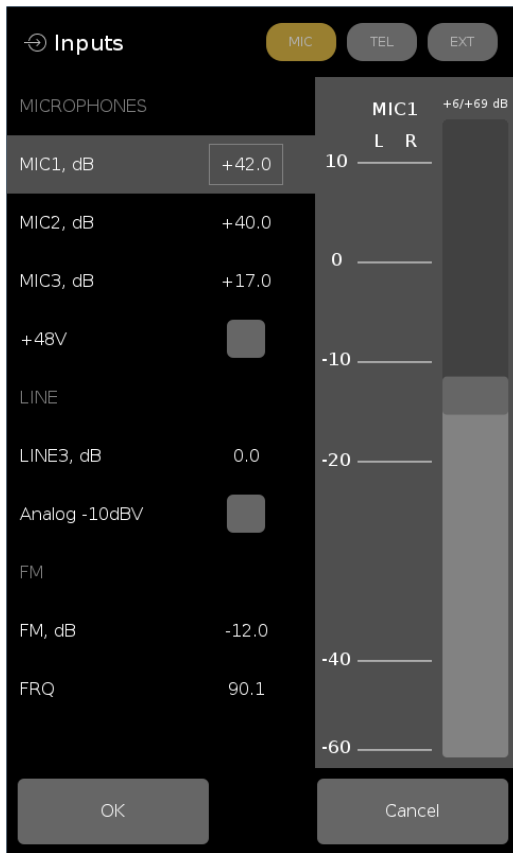

MIC1, MIC2, MIC3 - input gain lines for the three microphone inputs. Gain factors for input analog mic preamps are set using the digital value set in dB or the position of a virtual slider controller in dB. The adjustment limits are in the range of + 6 dB to + 69 dB with an adjustment step of 1 dB.

For three microphone inputs phantom power + 48 V can be turned on or off.

For the input **LINE 3**, the input divider transfer coefficient is selected. Input adjustment is set to +/- 24 dB.

You can immediately set the input sensitivity - 10 dBV by ticking the corresponding line.

For the **FM** input, the input adjustment is set to limits +/- 24 dB.

FRQ allows you to select the frequency of the **FM**-receiver.

The **TEL** button in the **Inputs** window opens the **TELEPHONE** window, which allows you to configure the **TEL** analog telephone line input or telephone input via Bluetooth - **BT**.

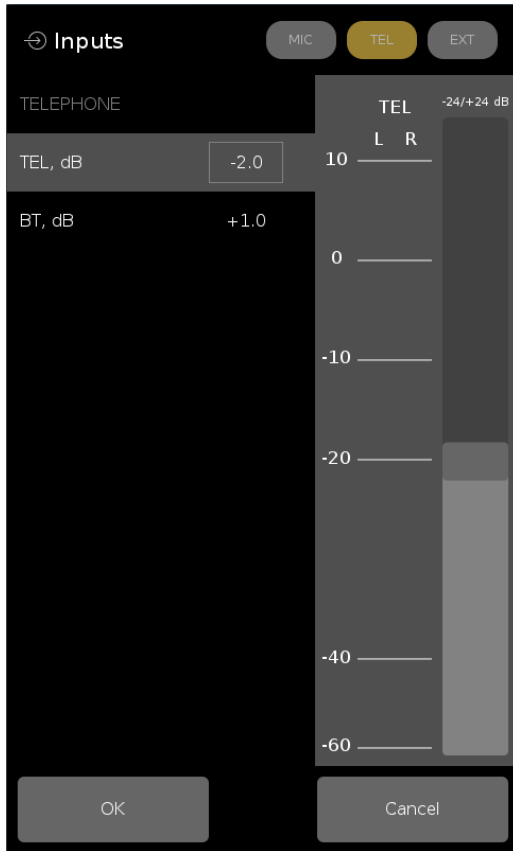

The input gain control is set to +/- 24 dB.

The **EXT** window helps to customize external channels.

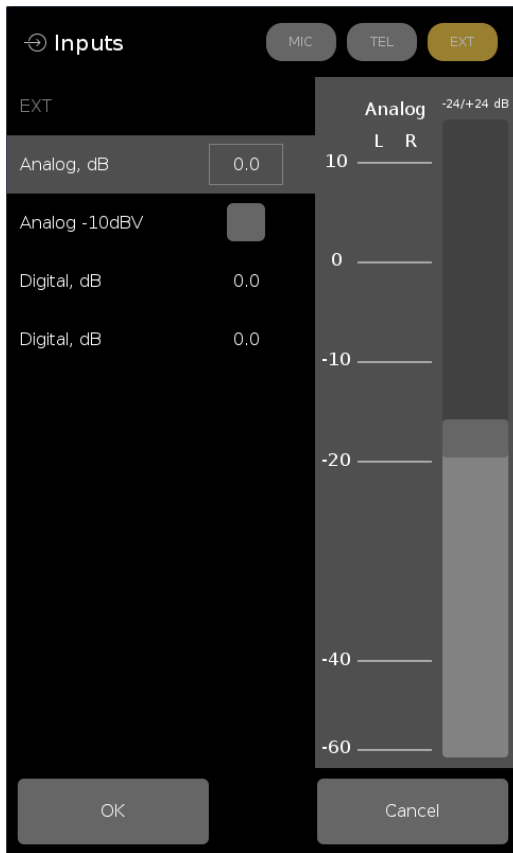

The **EXT** window allows to select the **Analog** input corresponding to a professional device with a balanced input and a nominal input level of + 4 dBu or a device with a unbalanced input and a nominal input level of 10 dBV. Input adjustment is also set to +/- 24 dB.

For the **DIGITAL** input the input adjustment is set to +/- 24 dB.

The **Outputs** window helps to customize the output channels.

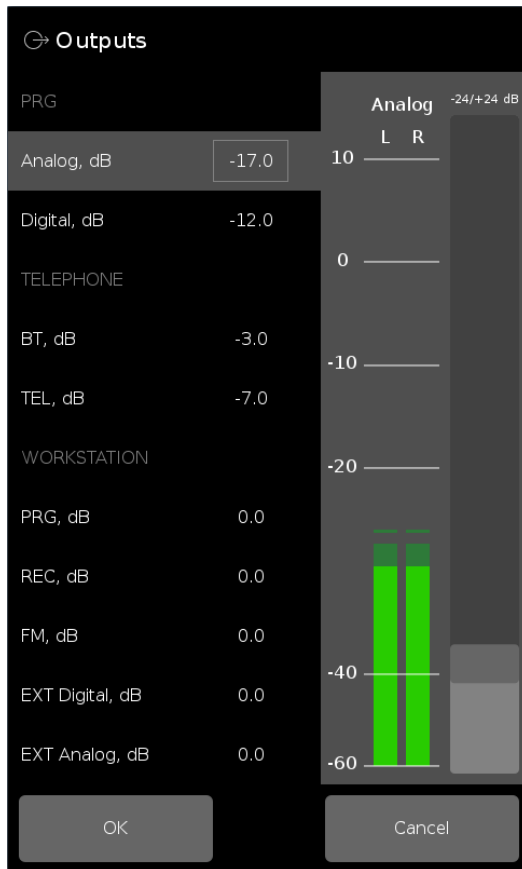

PRG are the main software outputs of **ANALOG** and **DIGITAL**. The adjustment range for each output is within +/- 24 dB relative to the level set for the program bus. The recommended level is + 4dBu (-20dBFS).

TELEPHONE allows you to set the adjustment on the **TEL** and **BT** outputs within +/- 24 dB relative to the nominal -20dBFS level.

WORKSTATIONS Channel Group: **PRG**, **REC**, **FM**, **EXT ANALOG**, **EXT DIGITAL** outputs are adjustable within +/- 24 dB relative to the nominal -20dBFS level.

The **System** window allows you to select a language (English, Russian), set the fader mode, shows technical information.

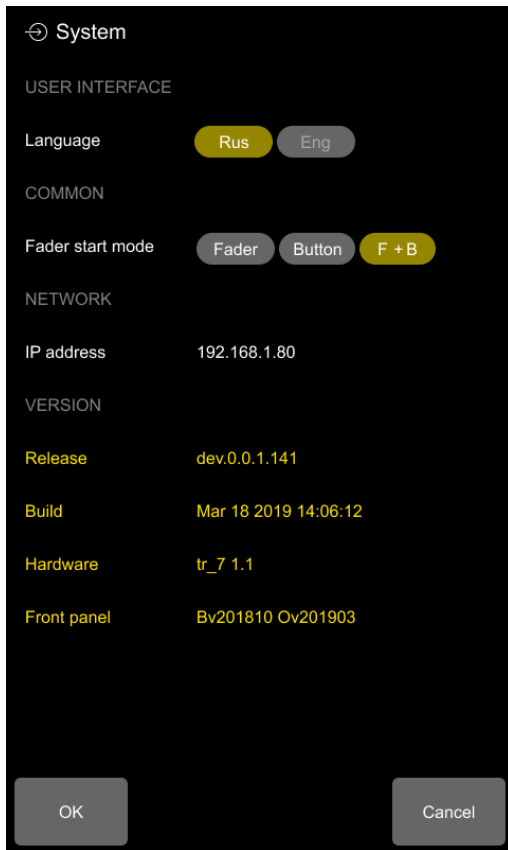

To change the language, press the button - **Rus** or **Eng**.

In this window, you can choose the fader mode by pressing the button: **Fader**, **Button** or **Fader + Button (F + B)**.

At the bottom of the window the IP- address displays and the information about the software version of the mixing console.

3.1.5 Web interface

The access to the web interface is provided from the workstation. To go to the web interface, it's necessary to enter the console's IP-address in the address bar of the browser (by default: 192.168.1.10).

The tabs of the web interface of the mixing console show the level indicators for all channels and windows of various settings are available.



AutoGain allows you to turn on the system to automatically lower the microphone signal level.

AG Threshold, dB provides entering a threshold value for **AG** triggering.

AG Gain step, dB provides entering the gain step.

MIC + 48V allows you to enable phantom power for microphones.

Analog, -10 dBV allows you to switch to an analog input with a nominal input level of -10 dBV.

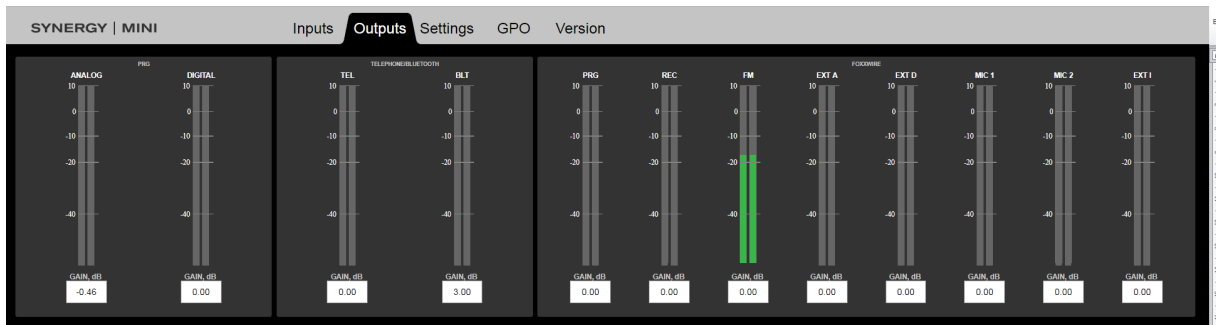

Web interface windows provide to enter values, select modes.



Also with web interface the firmware update is performed.



Settings that are available only in the web interface:

- Bluetooth module name;
- nominal level of indicators (in dBFs);
- AGC system control (automatic gain control);
- Output settings RJ45 F “GPO”.



3.2 Back panel

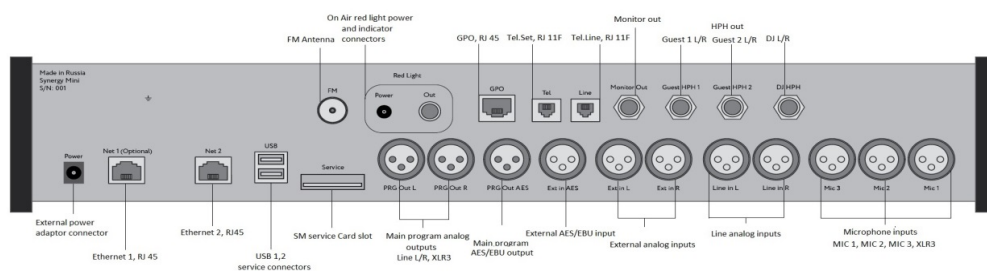

On the back panel of the SYNERGY MINI console there are connectors from left to right:

Top row:

- **FM** - FM antenna connector, GF-812 F type connector;
- **Red Light (Power)** - separate power supply for the scoreboard, type DS-221;
- **Red Light (Out)** - GPO signal to turn on the scoreboard, type RCA-F;
- **GPO** - 4GPO, RJ45 F connector;
- **Tel** - telephone, RJ11 F connector;
- **Line** - telephone line, RJ11 F connector;
- **Monitor Out** - control acoustic monitors, 1 * Jack ST F 6.3 mm jack;
- **Guest HPH1** - headset (Guest 1), jack 1 * Jack ST F 6.3 mm;
- **Guest HPH2** - headset (Guest 2), 1 * Jack ST F 6.3 mm jack;
- **DJ HPH** - headset (DJ), 1 * Jack ST F 6.3 mm jack;

Bottom row:

- **Power** - connection for an external power adapter, type DS-201 Dragon City Industries;
- **Net 1** (optional) - connection to the DANTE network (if available), RJ45 F connector;
- **Net 2** - connection to the Foxx Wire network and system network, RJ45 F connector;
- **USB** (upper) - keyboard connection;
- **USB** (lower) - supply power supply voltage + 5 V, current up to 0.5 A to external devices (for example: USB Sound Bar);

- **Service** - special slot for turning on the SM Card under the plug;
- **PRG Out L, PRG Out R** - main output: analog, stereo connectors 2 x XLR 3M;
- **PRG Out AES** - main output: AES / EBU, XLR 3M connector;
- **EXT in AES** - external input: AES / EBU, XLR 3F connector;
- **EXT in L, EXT in R** - external input: analogue, stereo, connectors 2 x XLR 3F;
- **Line in L, Line in R** - linear input: analogue, stereo, connectors 2 x XLR 3F;
- **MIC 3** - microphone: Guest 2, XLR 3F connector;
- **Mic 2** - microphone: Guest 1 XLR 3F connector;
- **Mic 1** - microphone: DJ, XLR 3F connector.

4 Channels

4.1 Microphone channels

Channels **1, 2, 3** are assigned microphone inputs on XLR 3F connectors, analog preamps with digital gain control ranging from +6 dB to +68 dB in 1 dB steps.

The **GAIN** input adjustment in each microphone channel is made through the corresponding tab of the TSD menu. In same tab of the menu, you can turn on **+48V** phantom power to all three microphone inputs when connected a condenser-type microphone.

Channel 3 also has a stereo line in (2 XLR 3F connectors).

In **Menu - Inputs** you can select a professional device with a balanced input and a nominal input level +4 dBu, or a device with a single-ended input and a nominal input level of 10 dBV is selected. In addition, there is a digital stereo preamplifier with an adjustment range from -24 dB to +24 dB in 1 dB steps. It is also possible to connect the output of the integrated FM-receiver with a digital adjustment range from -24 dB to +24 dB in 1 dB steps.

Switching between microphone No. 3, stereo line in and FM tuner is done by successively pressing the **M3 • L • FM** button in channel 3.

In each microphone channel there is a system that allows you to automatically lower the signal level – **AutoGain (AG)**.

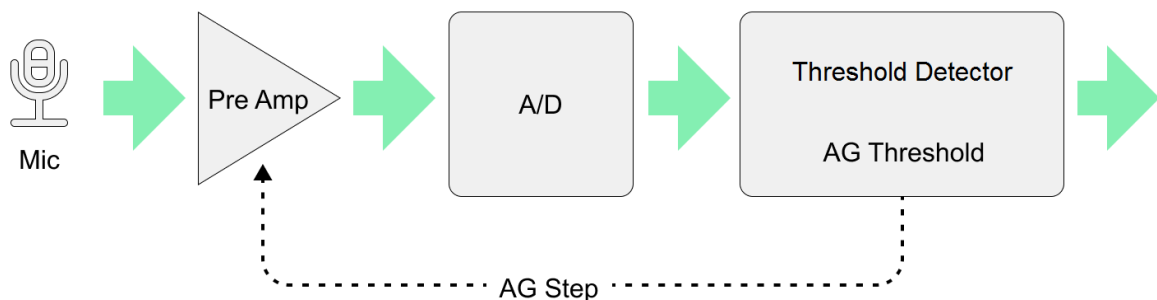

How the system **AG (AutoGain)** works:

- If the signal exceeds a set threshold level, the gain of the corresponding microphone preamplifier is reduced. The threshold value (**AG Threshold**) and the gain change step (**AG Step**) are configured on the Inputs tab of the web interface;
- When **AG** is triggered, the **Over** LED lights up in red;
- 3 seconds after the **AG** is triggered, the **Over** LED color in the channel changes from red to yellow, which informs the operator about the automatic gain reduction in the preamplifier of this microphone;

- At the same time, the **Over** button on the TSD is lit;
- Returning to the original gain value in this channel after no overload can be either manually adjusting the **GAIN** of this microphone channel in the TSD **Menu**, or by pressing the **Over** virtual button on the TSD. After that the LED on the console panel and the **Over** button go out.

The last manually set GAIN value is smoothly restored.

The main parameters of microphone channels:

- Phantom power voltage: +48 V;
- Input impedance of the microphone preamplifier: at least 4 kOhm;
- Input: electronic symmetry;
- Range of nominal input levels (source dynamic microphone): from - 65 dBu (0.4 mV) to - 57 dBu (1.0 mV);
- Range of nominal input levels (source condenser microphone): from -57 dBu (1.0 mV) to - 33 dBu (20.0 mV);
- Frequency range (pass-through channel: microphone input - analog input): - 20 Hz - 20 kHz (+0.5 / -0.5 dB);
- Equivalent integral noise, reduced to the microphone amplifier input: no more than - 127 dBu (with a source resistance of 150 Ohm).

The main parameters of the linear stereo channel:

- Input resistance of the preamplifier: at least 20 kOhm;
- Input: electronic symmetry;
- Nominal input level: + 4 dBu / - 10 dBV;
- Frequency range: 20 Hz - 20 kHz (+0.5 / -0.5 dB);
- Equivalent non-linear distortion + integral noise: no more than 0.008% (with an input signal + 18 dBu);
- Transient attenuation between L and R stereo channels: at least 80 dB in the frequency range - 20 Hz - 20 kHz.

4.2 Telephony channel

The fourth channel of the mixing console is a combined channel for receiving/transmitting signals when telephone subscribers are included in the on-air program.

The channel selects the type of telephone communication - traditional analogue telephony (analogue telephone hybrid) or GSM telephony which is supported by means of the built-in Bluetooth interface and GSM phone. This selection is made using **TEL** or **BT** buttons on the channel 4 panel. When the Bluetooth interface is selected, activation of the channel and communication with the GSM phone is confirmed by turning on the blue LED of the selection.

A separate digital bus PHONE N-1 (CleanFeed) is provided for generating a program signal for a telephone subscriber. The output of the PHONE N-1 (CleanFeed) bus is fed through two separately adjustable digital amplifiers to the "Send" input of an analog telephone hybrid and to the input of the Bluetooth interface.

Before including the subscriber in the program, you can first talk to the subscriber in duplex mode. At the same time, pressing the **PFL • TB** button for a preliminary conversation connects the No.1 DJ microphone while disconnecting the microphone from the program bus.

Analog telephone hybrid parameters:

For connection to the telephone line and to the telephone set 2 RJ11F connectors are installed.

Input levels of the audio signal received via the telephone line:

Nominal input level: - 27 dBu.

Minimum input level: - 40 dBu

Audio output levels, phone line output from PHONE N-1 bus:

Nominal output level: - 16 dBu.

Maximum output level: 0 dBu.

Frequency range: 300 Hz - 3400 Hz.

Frequency response: (300 Hz - 3400 Hz) +/- 3 dB.

THD: no more than 3%.

Bluetooth channel adapter for full duplex communication with a subscriber using a GSM mobile phone has the format of input / output signals I2S (4 wire bus). Adjustment of the input and output levels is provided by means of a digital processing unit ranging from - 24 dB to + 24 dB relative to the nominal level.

Bluetooth channel interface options:

- Nominal digital audio input level: - 20 dBFS (+4 dBu).
- Nominal digital audio output level: - 20 dBFS (+4 dBu).
- Signal-to-noise ratio at the input: at least 75 dB.
- Signal-to-noise ratio at the output: at least 90 dB.

4.3 External analog linear stereo input

One of the three inputs of channel number **8**.

The main purpose is to receive a retransmitted external program in the format of an analog stereo signal.

It has 2 XLR 3F connectors.

The main parameters of the external linear stereo channel:

- Input impedance preamplifier: at least 20 kOhm.
- Input: electronic symmetry.
- Nominal input level: + 4 dBu (1.23 V).

- Frequency range: - 20 Hz - 20 kHz (+0.5 / -0.5 dB).
- Equivalent non-linear distortion + integral noise: no more than 0.008% (with an input signal + 18 dBu).
- Transient attenuation between L and R stereo channels: at least 80 dB in the frequency range - 20 Hz - 20 kHz.

4.4 External digital AES/EBU stereo input

This is one of the three inputs of channel number **8**.

The main purpose is to receive a relayed external program in the format of a digital AES / EBU stereo signal.

It has 1 XLR 3F connector.

The main parameters of the external digital AES / EBU channel:

- Input resistance: 110 Ohm.
- Input: transformer balanced.
- Input stream: up to 24-bit / 32 kHz - 192 kHz, it is possible to convert the input sampling frequency (SRC) to an internal frequency of 48 kHz.
- Level range of input digital signals: from 0.2 V to 5 V - peak-to-peak.
- Nominal digital audio input level: - 20 dBFS (corresponds to +4 dBu), the input level is adjusted by means of a digital processing unit: from - 24 dB to + 24 dB.
- Dynamic range (Digital Inputs to Analog Outputs): 112 dB relative to 0 dBFs.
- Dynamic range (Digital Inputs to Digital Outputs): 126 dB relative to 0 dBFs.

4.5 External digital Internet stereo input

This is one of the three inputs of channel number **8**.

The main purpose is to receive a relayed external program in the format of an input Internet Streaming-stereo signal.

It is implemented in part by means of a workstation with the appropriate automation software installed and additional drivers: FoxxWire driver (8 stereo input / output AoIP channels) and driver system of local DAW control commands (SYNERGY MINI console).

Using TSD, you can adjust the input sound level (digital **Gain**) within +/- 24 dB.

4.6 Internal digital sound buses

The SYNERGY MINI mixing console has 5 internal digital audio stereo buses:

- **PROGRAM** digital stereo bus is the main bus of a digital stereo mix of the output program, to which the outputs of all 8 channels of the console are switched. The output of this bus is the input for all output amplifiers.
- Digital stereo **RECORD** is a separate digital stereo mix bus used to record a mix, independent of the main program, from sources that are outputs of channels 1 ... 7 of the mixer.
- **PFL** digital stereo bus (PreFader Listening / Monitoring of visual and acoustic sound signals from channels 1 ... 8 of the mixer to the faders). The PFL bus output goes to one of the inputs of the **MONITOR SELECT** digital switch.
- The **TALKBACK** digital mono bus is a special bus for organizing preliminary negotiations between the operator/DJ and telephone subscribers. **TALKBACK** bus has one source - channel No. 1 - DJ microphone. The signal on this bus comes from a point before the MIC 1 channel fader (it does not arrive on the **PROGRAM** and **RECORD** buses).
- The **PHONE N1** digital mono-bus is a special bus for generating a program signal for sending to a telephone subscriber. This bus receives for mixing the outputs of all channels of the console, except for the output of channel 4 - the telephone channel.

4.7 FM-receiver

The mixing console includes a single-channel FM receiver designed for visual and acoustic monitoring of the broadcast and for the possibility of submitting an on-air program to the logger.

The included adapter allows you to connect an external antenna with the F connector.

Parameters FM-receiver is determined by the appropriate command using TSD **Menu - INPUTS**.

4.8 Outputs of the mixing console

The SYNERGY MINI console has a main analog stereo output — 2 XLR-3M connectors and a main AES/EBU digital output jack — 1 XLR-3M connector.

Using TSD, you can adjust the output sound levels independently for analog and digital stereo outputs within +/- 24 dB.

Using TSD, you can adjust the output sound level to Internet streaming (digital gain) within +/- 24 dB relative to the nominal output level + 4 dBu (- 20 dBFS).

The main parameters of the output analog stereo channel:

- Type of outputs: balanced;
- Nominal output level: + 4 dBu;

- Maximum output level: + 24 dBu;
- Output impedance for each output no more: 50 Ohm;
- THD at the maximum input level: not more than 1%;
- Dynamic range: at least 80 dB (for max. Level).

The output level adjustment is made by means of a digital processing unit within +/- 24 dB.

The main parameters of the output digital AES/EBU channel:

- Output impedance: 110 Ohm;
- Output transformer balanced;
- Output stream: up to 24 bit / 48 kHz;
- Nominal digital audio input level: - 20 dBFS (corresponds to +4 dBu), adjustment of the output level by means of a digital processing unit: from - 24 dB to + 24 dB;
- Maximum digital audio output level: 0 dBFS (corresponds to +24 dBu);
- Dynamic range (Digital Inputs to Digital Outputs): 126 dB relative to 0 dBFs.

Output to external acoustic monitors

The SYNERGY MINI has one unbalanced stereo output - 6.3 mm Stereo jack for connecting external acoustic monitors.

The output level adjustment is provided by means of the digital processing unit of the mixing console.

The main parameters of the monitor outputs:

- Output impedance: not more than 36 Ohm;
- Nominal output level: + 4 dBu;
- Maximum output level: + 18 dBu;
- Frequency range: 20 ... 20000 Hz;
- Dynamic range: at least 80 dB;
- THD at the maximum input level: not more than 1%;
- Signal / noise ratio to + 4 dBu level: at least 70 dB.

Output level adjustment range: from - ∞ dB to + 10 dB.

Headphone output

The SYNERGY MINI console has an unbalanced stereo output - JACK ST connectors of 6.3 mm for connecting three pairs of headphones for DJ, guest 1 and guest 2.

The output level independent adjustment for each of these three outputs is provided by means of the digital processing unit of the mixing console.

The headphone connectors for DJ, Guest 1 and Guest 2 are located on the back of the mixer.

The main parameters of monitor outputs on headphones:

- Output impedance no more: 32 Ohm;
- Nominal output level: - 8 dBu;
- Maximum output level: + 4 dBu;
- Frequency range: 20 ... 20000 Hz;
- Dynamic range: at least 80 dB;
- THD at the maximum input level: not more than 1%;
- Signal / noise ratio to + 4 dBu level: at least 70 dB;
- Range of adjustment of levels of output signals: from - ∞ dB to + 10 dB.

5 Connectors

On the back panel of the SYNERGY MINI console, from left to right (in the upper and lower rows) there are connectors:

- **FM** - FM antenna, HYR-0812 (GF-812) F type connector;

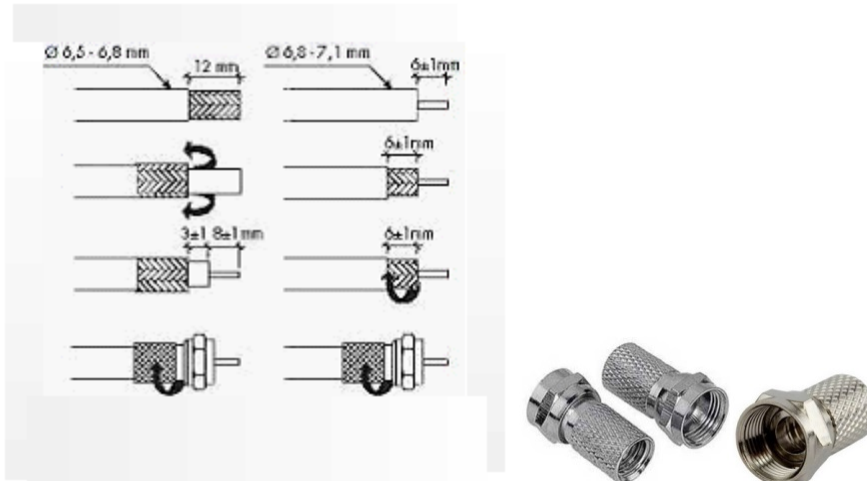

Braid (shield)



Cabel core

- **Red Light (Out)** - signal to turn on the scoreboard, RCA-F;



- **GPO**- 4GPO, RJ45 F connector;

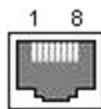

Pin number	Signal	Twisted pair wire color (straight cable, EIA/ TIA-568-B)
------------	--------	--

1	GPO1- (emitter)	white-orange
2	GPO1+ (collector)	orange
3	GPO3- (emitter)	white-green
4	GPO2+ (collector)	blue
5	GPO2- (emitter)	white-blue
6	GPO3+ (collector)	green
7	GPO4- (emitter)	white-brown
8	GPO4+ (collector)	brown

- **Tel** - telephone connector RJ11 F;
- **Line** - telephone line, connector RJ11 F;

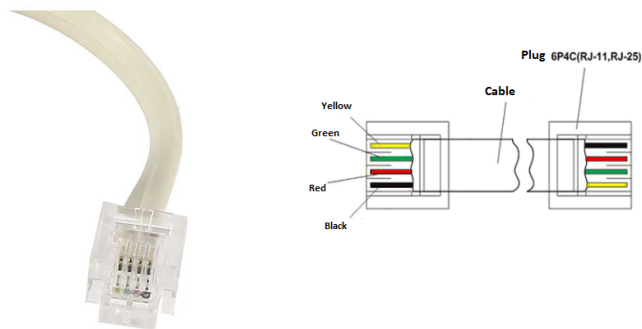

- **Monitor Out** - control monitors, connector Jack ST F 6.3 mm;
- **Guest HPH1** - head phone (Guest 1) connector, Jack ST F 6.3 mm;
- **Guest HPH2** - head phone (Guest 2) connector, Jack ST F 6.3 mm;
- **DJ HPH** - DJ head phone connector, Jack ST F 6.3 mm;



Pin number	Signal
T	left
R	right
S	Ground(GND)



- **Red Light (Power)** - separate power supply for the scoreboard;

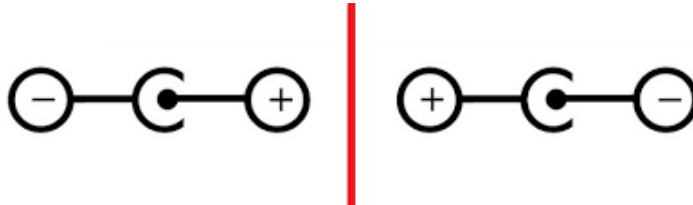

Diameter outer 5.5 mm, inner diameter 2.1 mm

- **Power** - external power adapter connector, type DS-201 from Dragon City Industries;

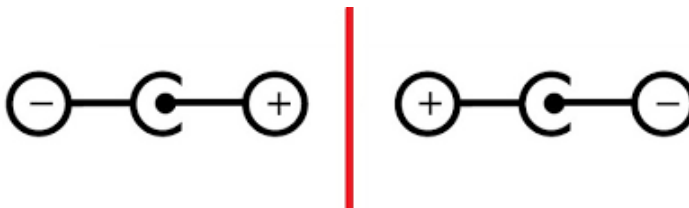

Diameter outer 5.5 mm, inner diameter 2.1 mm

- **Net 1 (optional)** – to connect to the DANTE network (if available), connector RJ45 F;
- **Net 2** – to connect to the FoxxWire network and system network connector RJ45 F;



- **PRG Out L, PRG Out R** - main output: analog, stereo connectors 2 x XLR 3M;
- **EXT in L, EXT in R** - external input: analog, stereo, connectors 2 x XLR 3F;
- **Line in L, Line in R** - line input: analog stereo connectors = 2 x XLR 3F;
- **MIC 3** - microphone: Guest 2 connector XLR 3F;
- **Mic 2** - microphone: Guest 1 connector XLR 3F;
- **Mic 1** - microphone: DJ connector XLR 3F.



Pin Number	Signal
1	GND
2	+(plus)
3	-(minus)

- **PRG Out AES** – main out: AES/EBU, connector XLR 3M;
- **EXT in AES** – external in: AES/EBU, connector XLR 3F;

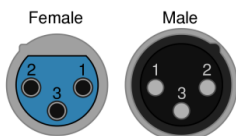

Pin Number	Signal
1	GND
2	+
3	-

6 Remote control, broadcast alarm and power supply

In the back side of the mixing console there are connectors related to the remote control system, broadcast alarm and power supply of the console.

Through the RJ45-GPO connector the console generates signals for external devices (4xGPO). In the web interface on the GPO tab, settings for the operation of these outputs are available (see the [Web interface section](#)³⁰¹ of the console).

To the output “Red Light (Out)” of the mixing console you can connect a light signaling panel to indicate the opening of the microphone channel.

The company "Tract" produces the following models of illuminated panels: TR-ML, TR-OA, TR-142. In the basic version there are the inscriptions “MIC LIVE” and “ON AIR”.

The external light panel can be connected to the mixer in two ways:

- **Using an additional power supply.** When using an additional power supply unit, the light panel is connected to the RCA-F “Red Light (Out)” connector. An additional power supply is connected to the “Red Light (Power)” power jack. The light panels of the company “Tract” operate from a constant voltage of 12V, the power supply unit “Airlight ARD V-12-12A, 12V, 1A, 12W” can be optionally included, suitable for working with them. To connect light panel of other manufacturers, pay attention to the technical characteristics of the output “External Red Light Output (RCA Out)” shown on the diagram.
- **Using the panel control unit.** The company "Tract" produces TR-141 unit designed to control light panels from standard signaling circuit outputs (dry contact) of broadcast consoles and other studio devices.

The principle of connecting the power supply to the scoreboard

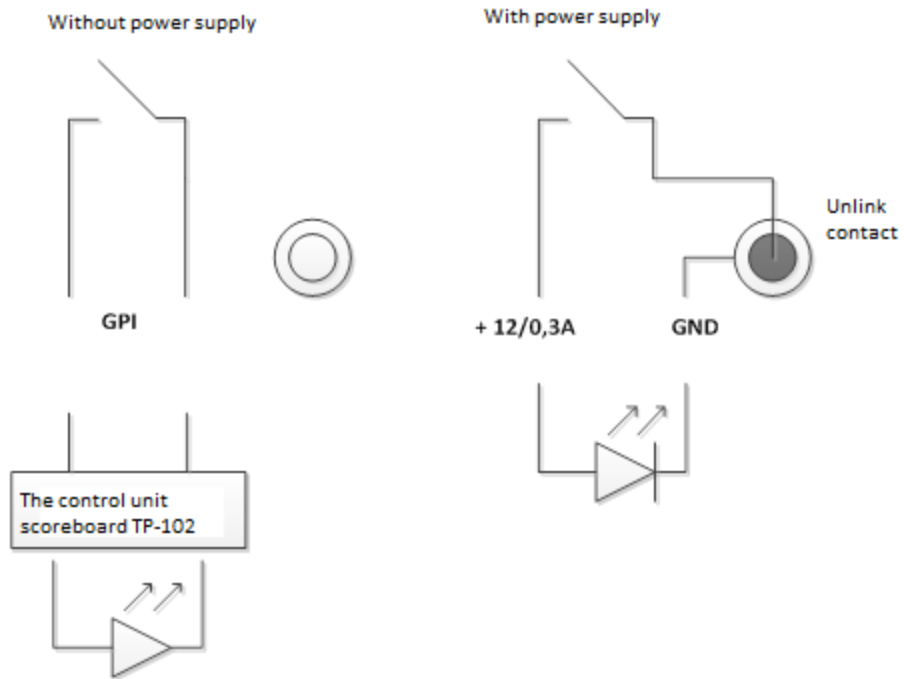

Without power supply to the “Red Light (Power)” power socket, the output for the light scoreboard works in GPO mode. The input connectors of the TR-141 “Control” unit A or B are connected to the output of the RCA-F console “Red Light (Out)”.

The power supply of the console is produced from an external stabilized supply voltage of 12V and current up to 2A through the Power connector, type DS-201 from Dragon City Industries.

7 REC 1, REC 2, REC 3 modes

The buttons REC 1, REC 2, REC 3 are intended for recording broadcast material.

Each button is assigned a specific recording mode.

When switching modes REC 1, REC 2, REC 3, the fader is linked to the channel and the channel is switched to another bus.

During live broadcast signals from all sources go to the PRG bus and on the air.

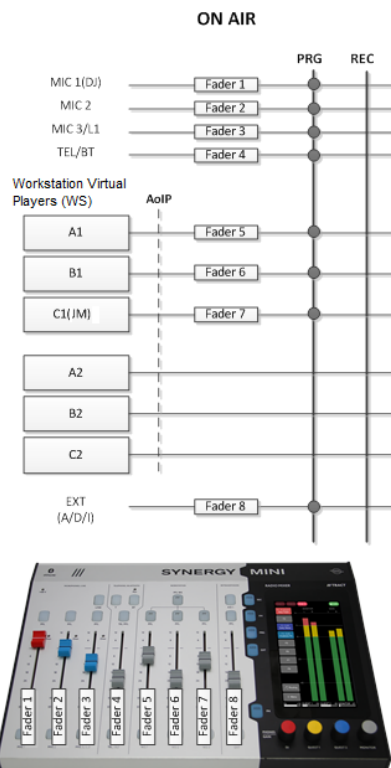

REC1

The mode allows you to record programs for broadcast during the live air. Channels (WS A1 - WS C1) remain on the PRG bus and continue broadcasting. On WS A2-WS C2 channels signals are given from individual players, which are used only for recording. These channels are controlled by the faders 5, 6, 7. This may be a different program configuration that works simultaneously with the main or even other software.

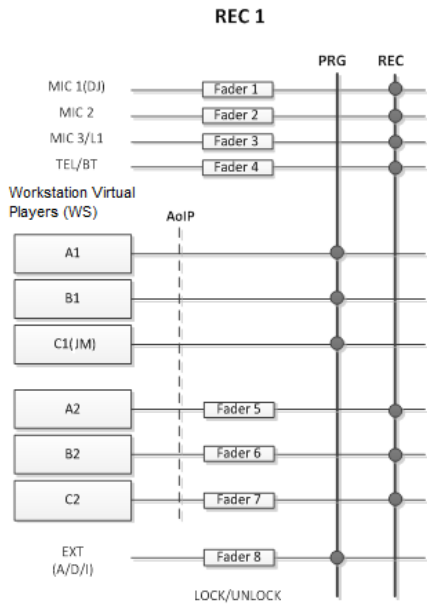

In a telephone conversation, the signal from MIC 1 (DJ) and TEL/BT channels go to the REC bus, and not to air.

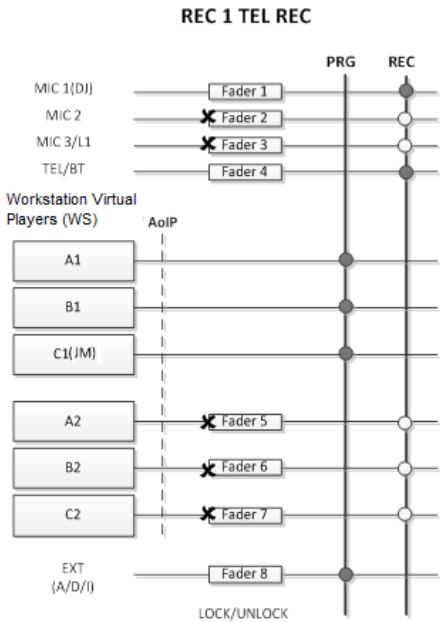

The **REC 1** mode is also used to record VoiceTrack when no signal is sent to the WS A2-WS C2 and all 3 faders are used for control.

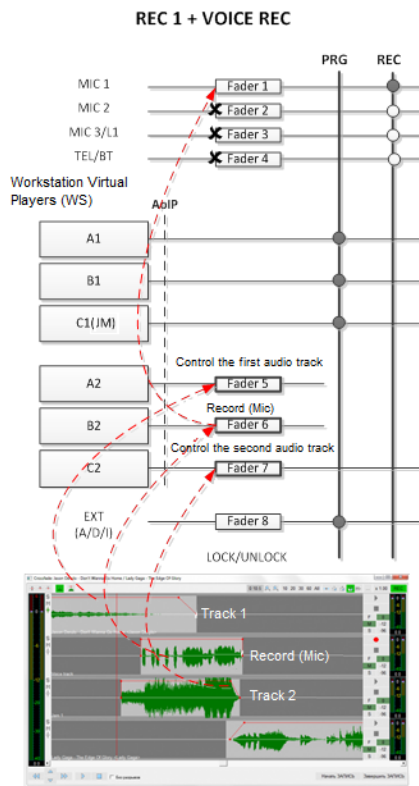

REC2

In **REC 2** mode fader 7 still controls the channel WS C1, which is playing the Jingle Machine, used for both broadcasting and recording. However, during recording the Jingle Machine channel is transferred to the **REC** bus.

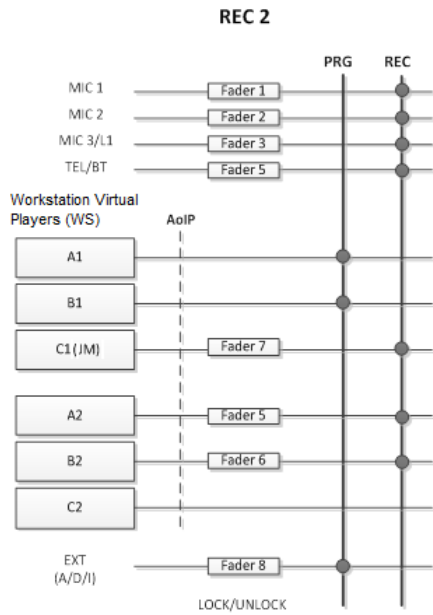

REC3

In this mode, the output of all channels is transferred to the REC bus as it happens with microphone channels. This is useful if the broadcast goes through the channel **EXT**.

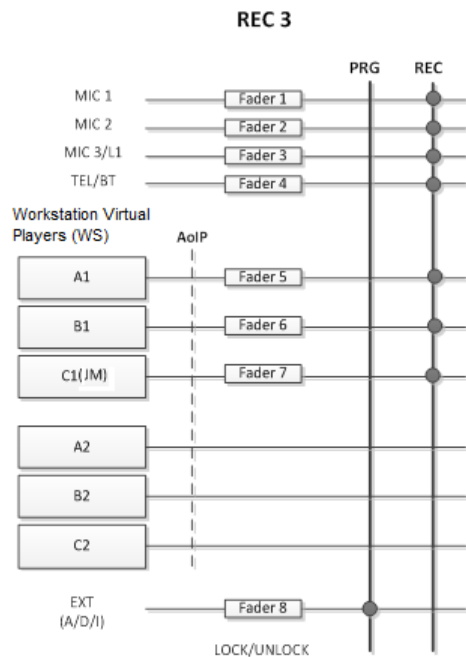

All other players and Jingle Machine are used only for the live broadcasts and can be used both during the broadcast and during the recording.

8 Updating the software version

The image of the operating system and firmware are recorded on the microSD card during production.

The firmware update is performed via Web interface. The current firmware version can be found on the [SYNERGY MINI](#) page.

You can find out the version of the mixing console firmware through the menu on the LCD screen: **Menu - System - Release**

To upgrade the firmware you need:

- Connect the network interface of the Net2 console with the patch cord to the network card of the workstation;
- Configure the network interfaces of the mixing console and the workstation;
- Access the web interface using a browser on a workstation;
- Go to the Version page in the web interface. Here is information about the firmware version;
- Download the firmware file using the **Select file** button and click the **Update software** button.

A few minutes after the update procedure is completed, the mixing console will reboot and will be ready for operation.

Service - a special slot to connect the SD Card under the plug on the back of the console. If it is necessary to replace the SD Card, please, contact technical support at support@tract.ru.

9 Software supplied with SYNERGY MINI

The following software is supplied with the SYNERGY MINI console:

1. ASIO driver,
2. DJin SYNERGY,
3. IAudioService.

Scheme of applications communication with the mixer

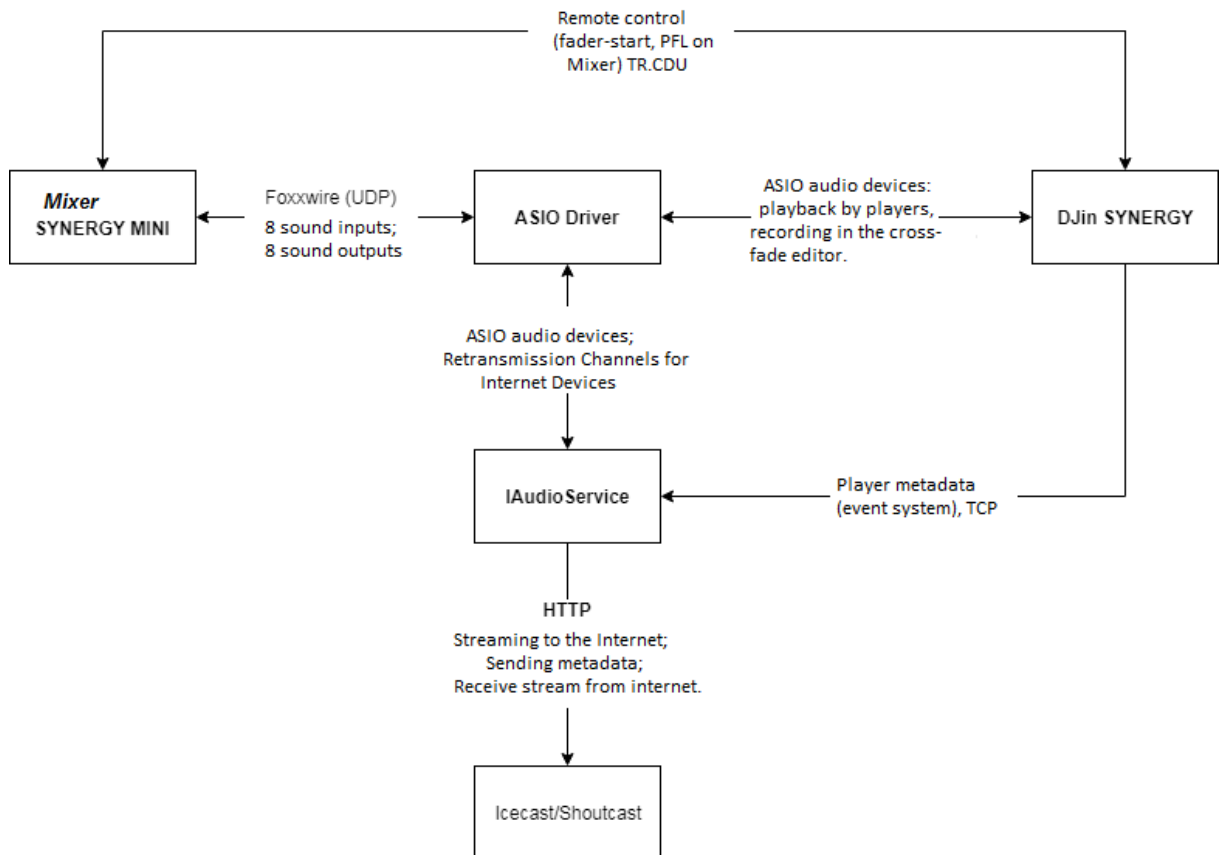

9.1 Diagram of connection via network

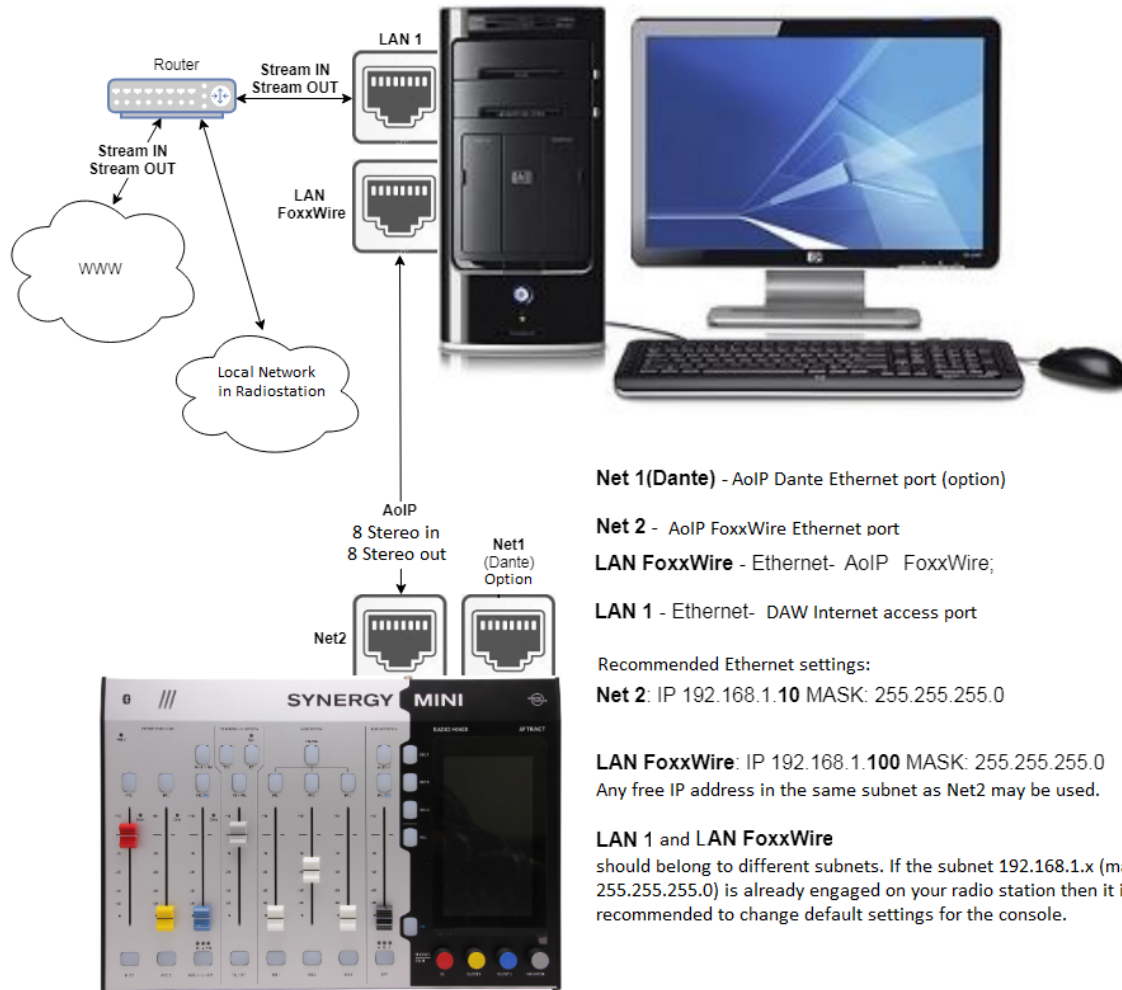

9.2 DIGISPOT II SYNERGY Installation and configuration

For full operation of the console and its applications, you must correctly configure the network card (IP-address, subnet mask).

To configure the network card, go to the **Control Panel - Network and Internet - Network and Sharing Center - Change adapter settings** and configure the settings of the network card with which the console will work.

In the properties of the local area connection you should specify the components necessary for work:

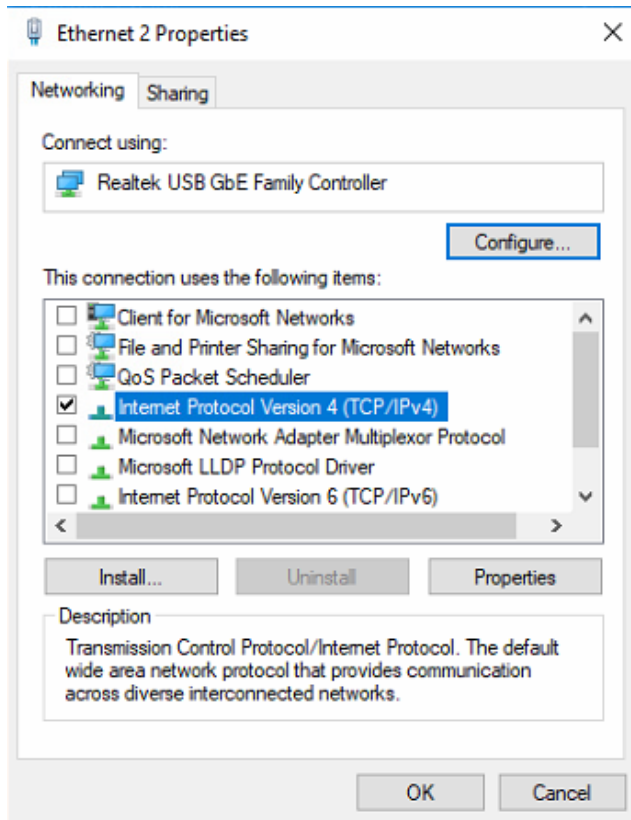

In the properties of the protocol you need to specify the IP-address and subnet mask. To save the changes, click **OK**.

The network card must be on the same subnet as the mixing console.

For the console use a separate network card.

After configuring the network card you need:

1. Run the software installation using SYNERGY_MINI.exe and follow the program instructions.
2. Select the folder in which to install the components.
3. Specify the IP-address of the mixer (specified in **Menu - Remote system**) and select the configured network card.
4. In the window that opens, check the applications you need to install (by default all are checked):

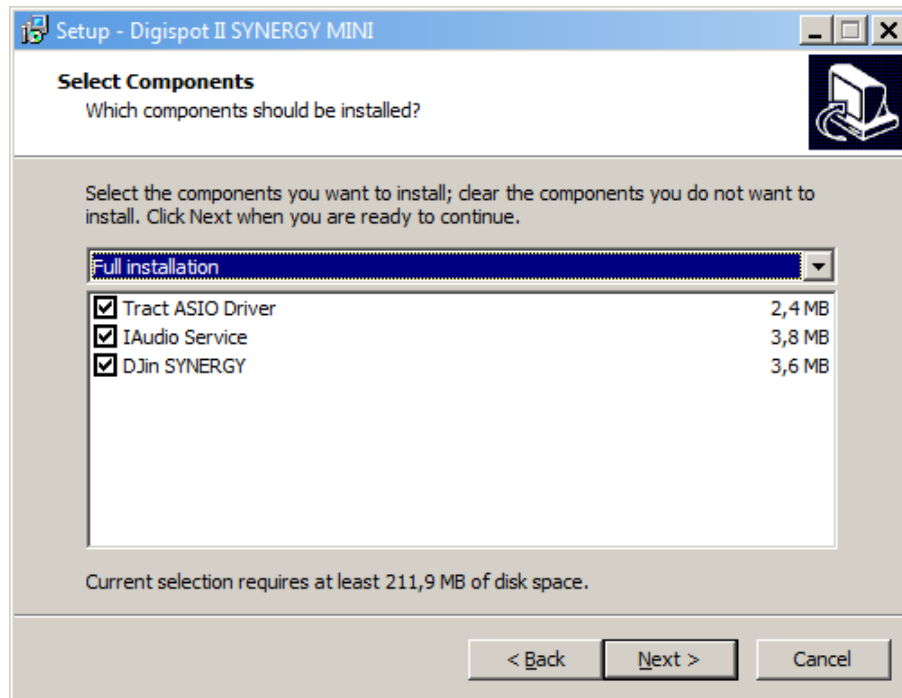

When installing Tract ASIO Driver, the driver is configured automatically.

Installing the Tract ASIO Driver component is optional if the Tract ASIO Driver was previously installed on the computer (in this case, you need to configure the installed ASIO driver).

Installing the IAudio Service component is optional if you do not plan to use the Internet broadcast.

5. Following the instructions of the program, complete the installation

9.2.1 DJin SYNERGY

DJin SYNERGY is a special version of DJin Lite that has some features:

DJin SYNERGY can work only with the SYNERGY MINI console;

- DJin SYNERGY has no restrictions on the number of days of planning, but the key restrictions remain: one schedule, which can only be edited locally; no MDB; no administration system; cannot edit configurations; no options;
- DJin SYNERGY has limitations on the list of audio devices available in players. You can use only the channels of the SYNERGY MINI console.
- DJin SYNERGY has three configurations:
 - **DJin: Air-X Live**, built on the base of the X-Player and focused on its own broadcasting. The user, working as a presenter, DJ or editor, can broadcast, create a schedule, edit crossfades, etc.
 - **DJin 777**, built on the base of the 777 retransmission block and intended for organizing a signal retransmission with automatic insertion of local commercial by time, DTFM-marks or

manually. The user, working as an operator of the air, editor or traffic manager, can create a schedule of local commercial frames, automate the process of broadcasting and control the air.

- **A simple player**, built on the base of a block player and intended for playing small playlists. The user can create a mini-playlist, “glue” the phonograms and broadcast.

About the features of the work of these DJin configurations can be found in the User Manual.

9.2.2 IAudio Service

For the organization of Internet streaming, the AudioService application is used (it is installed with the other components, unless the check mark has been removed during the installation process).

After starting the application with administrator rights, you should configure the IAudio Service.

In the service settings you need to make additional settings for the ASIO driver:

In the installed drivers select the Tract ASIO Driver device, enable **Autoload** and **Autostart**, click **Load**.

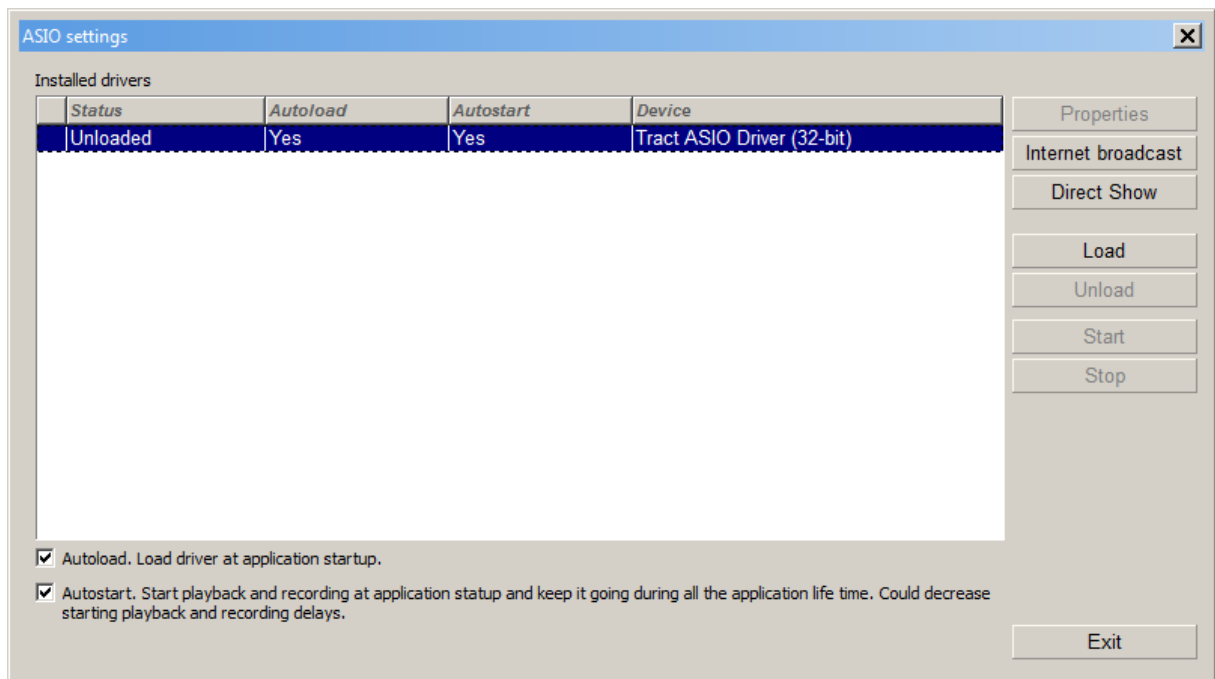

Pressing the **Internet broadcast** button, you need to add devices to stream and receive Internet streams.

After that set up the retransmission channels.

To ensure Internet broadcasting when creating a retransmission channel, in the Parameters, you need to specify - **ASIO: Tract ASIO Driver (32-bit) :(1/2) -REC # 0** as a recording device.

To get an online stream, you need to specify as a playback device - **ASIO: Tract ASIO Driver (32-bit) : (15/16) -PLY # 14**.

Retransmission channel settings

Name
INT

Recording device
ASIO: Tract ASIO Driver (32-bit):(1/2)-REC#0

Playback device
ASIO: Tract ASIO Driver (32-bit):(15/16)-PLY#14

Keep playback device open
 Software data transfer

Software data transfer buffering (ms)

Minimum	Normal	Maximum
200	600	1000

Signal delay

Temporary folder
[] ...

Signal delay (hh:mm) 00:00

Signal delay
 Use for monitoring in sound editor

OK Cancel

Complete the setup following the instructions.

If the setting is correct, the indicator will appear on the console display.

Additional information is available on the website <http://news.digispot.ru> or in the technical support service support@tract.ru.